

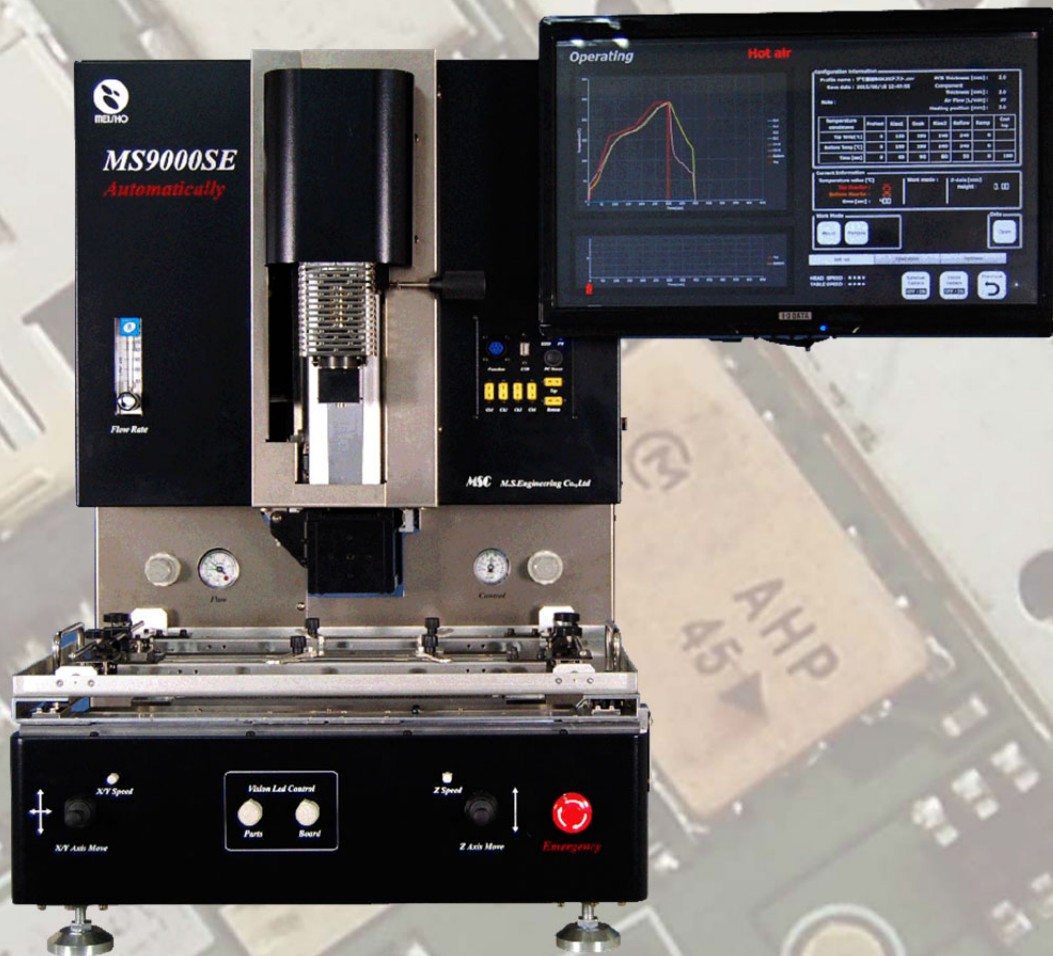

Multi-Ways Rework Station

MS9000SE

- **Air & IR heating are Possible**
- **Flat Package & Chip Components are Possible**
(2x2 to 50x50 & 01005(0402) to 0805(2021))
- **All-Reworking Processes is Possible**
(Removing-Cleaning-Printing-Replacing-Soldering)
- **Auto-Thermal Profile System (ITTS)**
- **Digital Image Matching System (CDPS Auto-Positioning)**
- **Auto-Solder Cleaning (Double Cyclone Suction System)**
- **Full-Auto Reworking:(Remove-Pick-up-Printing-Positioning-Mount)**



MS9000SE: Multi Ways Rework Station (CE model) Catalogue (Ver.8.0)



Overview

MS9000SE is the all-round rework system which almost all SMD can be reworked. And the original ITTS auto profiler system is operates of the system easily and exactly. Many kinds, such as a connector, and a socket, a shield cover, of SMD can be reworked as well as BGA and CSP, and also QFP of a fine pitch.

Furthermore, if the adapter of a separate item is used, reworking of chip components such as 0402 (01005) etc. is also available. (

Main Features;

- Top heater system can be changed to the **Air** and **IR**
- Reworking for chip components of **01005** to **0805** also possible.
- It has the function of all-reworking processes.
(Removing-Cleaning-Printing-Replacing-Soldering)
- Newell **ITTS** (Intelligence Thermal Trace System)
- Digital Image Matching System (CDPS Auto-Positioning)
- **Under-fill Package** Reworking (Narrow Heating Nozzle)
- Solder Cleaning (Double Cyclone Suction System)
- Fully-Auto Reworking **(Remove, Pick-up, Printing, Positioning & Mount)**

***Easy Changeable of Top Heater System (IR is option)**



By Hot Air Heating

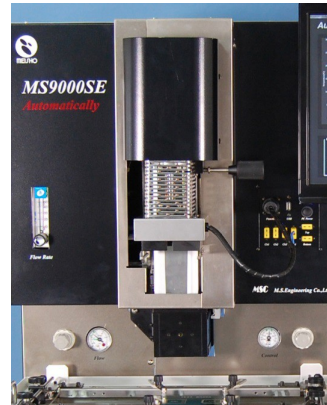

By IR Heating

If the heating nozzle of a top heater is removed and it equips with IR heating unit, a top heater of equipment will be IR. Exchange of the IR unit is easy at one-touch. If IR unit is connected, a control screen will be automatic and will change to IR control screen. The top heater of a normal machine is an **Air system**.

***Reworking of a Package type component.**

A reflow nozzle **MS9000SEnz 0000** reworks SMD, such as almost all BGA. It prepares in accordance with the size of a package. If the size of a nozzle is changed, it can rework from 2x2 to 50x50-mm of SMD.

The size of nozzle goes into 0000 of a model number. And 0000 is an inside diameter of the nozzle. For example, in the case of MS9000SEnz1616, It is for the 15.0x15.0-mm CSP. In usual, the size of a nozzle adds 1.0 mm to the outline size of parts.



MS9000SEnz0000 Nozzle

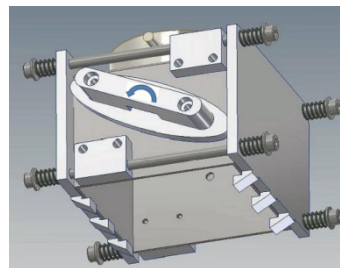

for POP Nozzle



for Under-fill Nozzle

***In the case of POP, (MS9000SEnz-POP)**

A special nozzle can be arranged for POP component. The component is held and taken not by vacuum but by a claw.

*** In the case of Under Fill Package, (MS9000SEnz-UFN)**

MS9000SEnz-UFN is nozzle for a package with under-fill. Overheating of next parts is kept away by the exhaust way of MS9000SEnz-UFN hot air heating.

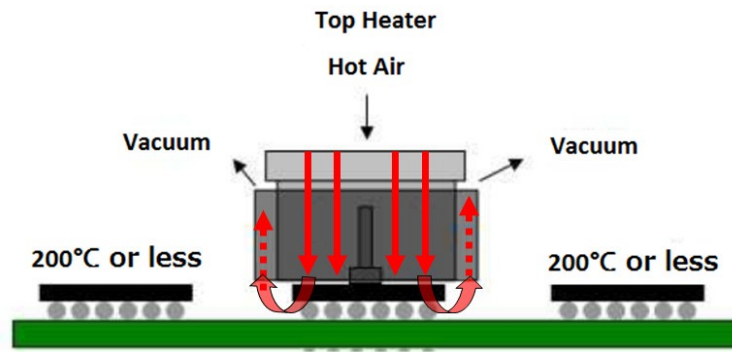

If away (about 1mm) with the next components, the difference in temperature of about 40 degrees will be got.

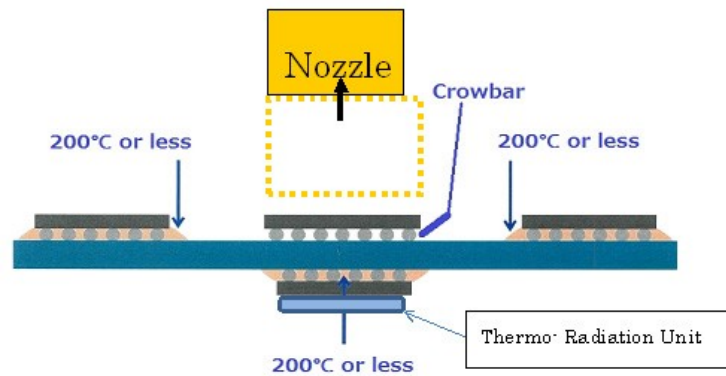

***MS9000SEnz-TRM Thermal Radiation Unit.**

The difference in temperature of about 40 degrees will be got by wearing of MS9000SE-TRM when the reverse side of a board has the package.

Size of a nozzle: There are two kinds of size.

MS9000SEnz-UFN can be used to a ≤ 5.0 x 5.0mm to 11.0 x 11.0mm package.
Exchange of the nozzle hood is possible for it.

MS9000SE-UFN-L can be used to a 12.0 x 12.0 to 20.0 x 20.0mm package.
Exchange of the nozzle hood is possible for it.

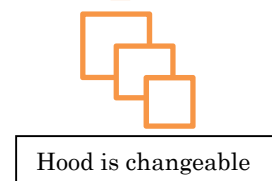

***Reworking of a Chip size component. (Option)**

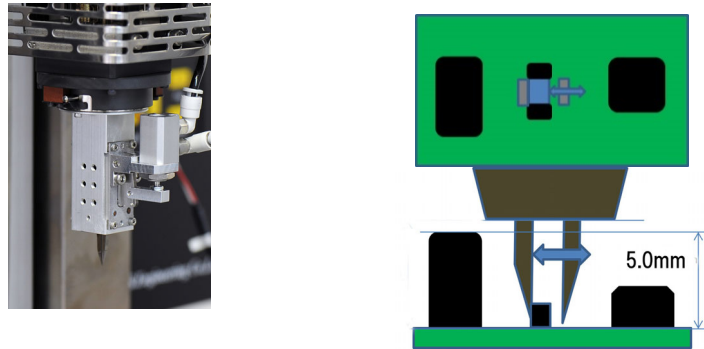

Tweezers Nozzle by Air

When reworking SMD of chip size, it changes into a reflow nozzle and uses a tweezers nozzle. It can be rework to the chip components from 01005 to 1206(inch). Only by a spacer exchanging, it responds to each size of parts in which sizes differ. The height of the standard tweezers nozzle is 5 mm.

It will be necessary to heat by N2 gas in soldering of microscopic parts, such as 01005. The generator of N2 gas is also prepared as the option.

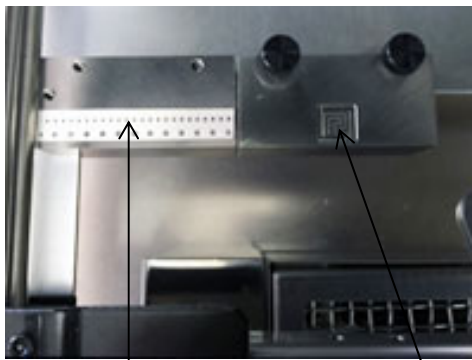

8mm Taping Parts Supply-Tool with solder pool.

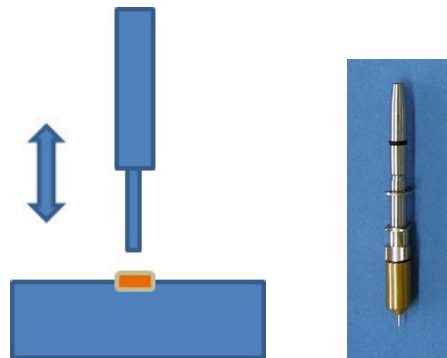

Pick-up Pin MS9000SE-CPTP

The pickup pin of taping parts and the transfer pin of solder printing are included in the set. And they can also be used for three kinds of chips. (01005/0201/0402) The palette for picking up free-parts is also attached to the set.

Printing of solder is a transfer system. It transfers from the transfer tool of the solder included in a set, or the solder pool of SND-N of accessories

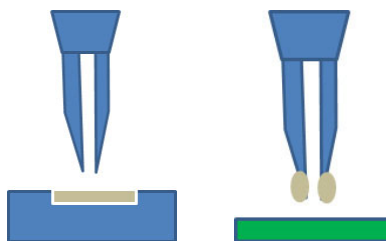

Solder Printing Pin MS9000SE-CPP



SND-N Solder Print Tool

*Solder Cleaning (Option)

The land of a board is cleaned.

The cleaning in manual operation or a non-contact auto-operation is possible.

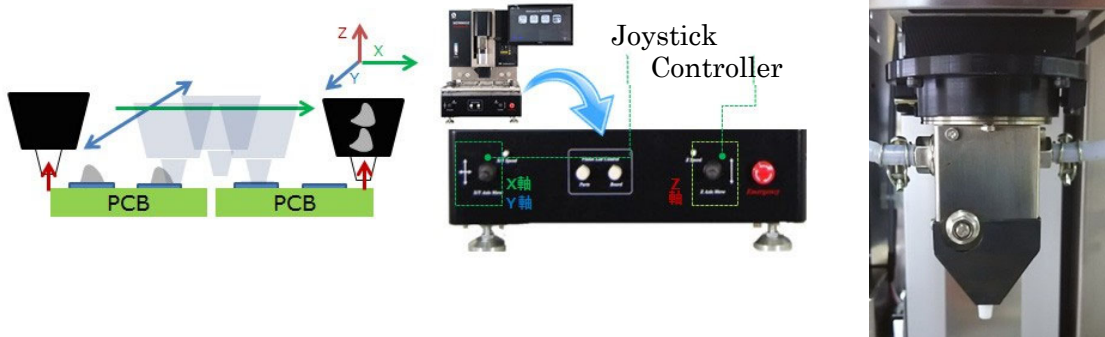

Non-Contact Auto-Cleaning for Package land.

The clearance of the board and the nozzle is automatically kept constant. It is controlled so that vacuums pressure becomes constant inside the nozzle. And, by the double cyclone suction system, solder is sucked up powerfully.

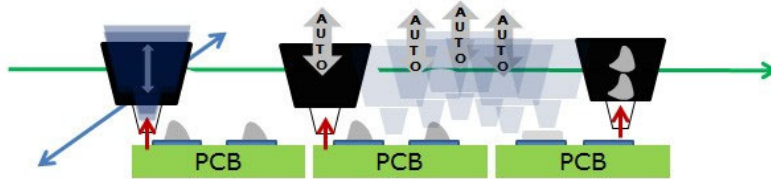

Flat-contacted

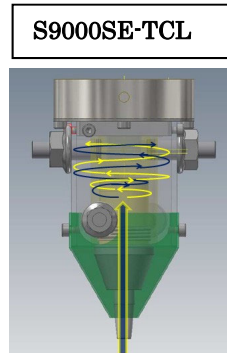

Double-Cyclone

There is an original cleaner head which smooths the surface of solder level. It is the purpose to smooth the irregular upper surface level in what that remains on a land. It is not necessary to melt the solder.

* Solder Printing For Package:

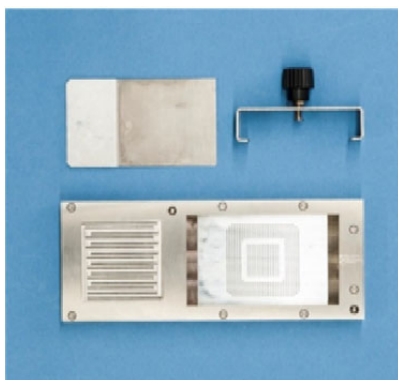

SND-N (Printing Tool)

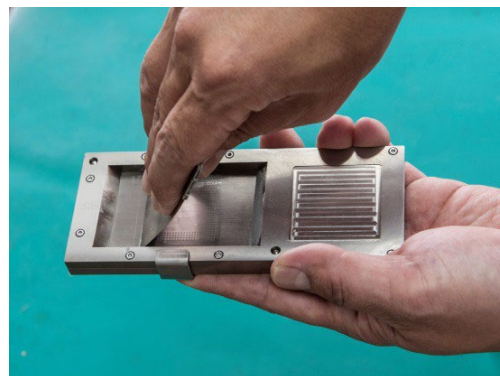

Squeezing

In BGA, It uses a printing tool for the package, and prints the solder-paste. MS9000SE vacuumed of the printed package from the printing tool automatically. In SND-N, printing of a transfer type is also possible. In that case, probably, the solder paste should use for transfer.

In BGA, It uses a printing tool for the package, and prints the solder-paste. MS9000SE vacuumed of the printed package from the printing tool automatically. In **SND-N**, printing of a transfer type is also possible. In that case, probably, the solder paste should use for transfer.

Model **SND-N** has two functions, one is printing by metal mask, and other one is by transcription.

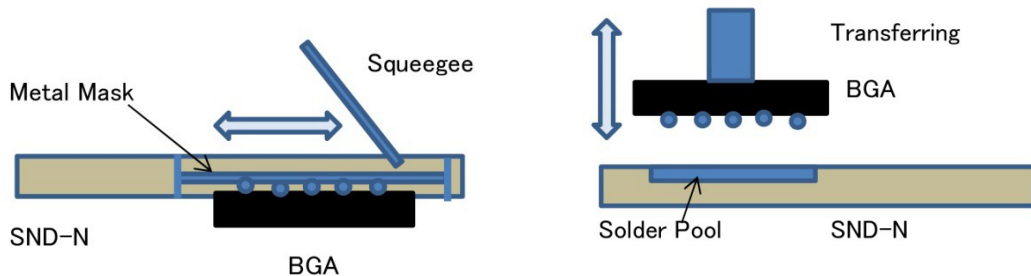

The special printing tool MS9000SE-**CPP** is prepared for the fine size parts such as 01005.

And the solder printing pin MS9000SE-**CPP** provided suitable amount of solder paste to the land.

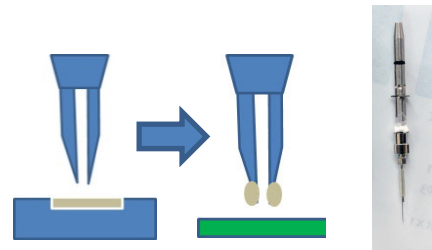

* Vision System (principle of positioning.)

The function of the positioning is very important of the rework station. It must be able to respond to large-sized BGA etc. from the fine components of chip size.

In MS9000SE, the image of components and the land of a board is expanded and monitored with a CCD camera with high resolution ability.

And XY table is adjusting finely and it is made for each image to overlap.

The performance of positioning must have the high accuracy of both a vision and a mechanism. MS9000SE has enough match ability also for the 01005 or less new component.

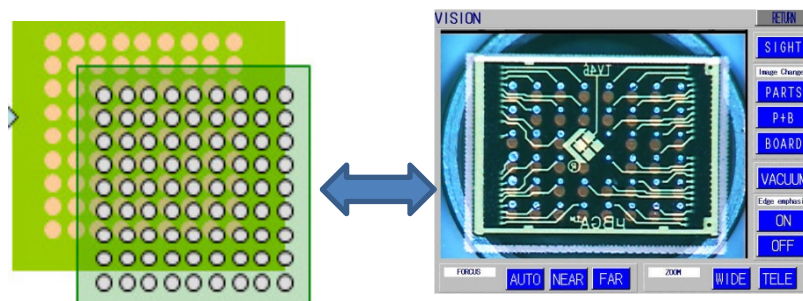

Positioning will be completion if the image of the board and parts on the monitor is made to accord. And it is operated by fine adjusting of XY table. The calibration by oneself, because the tool for calibration is attached – therefore the system can always operate correctly.

* Auto Positioning Vision System (Option)

Two cameras are used in the newly developed next-generation vision system.

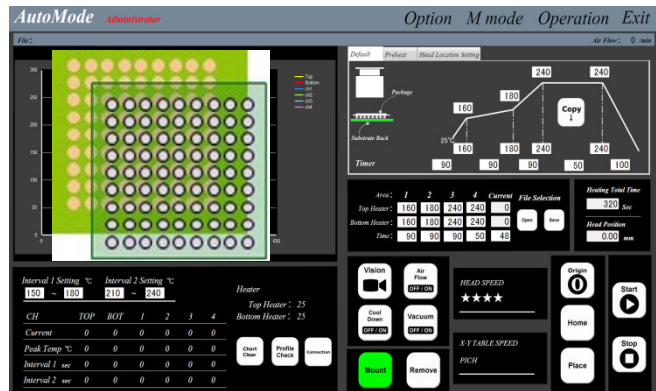
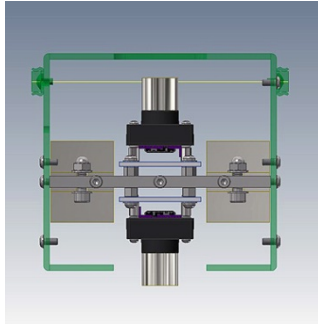

If a worker clicks the center section of four magnified images of ABCD on the monitor, it will calculate automatically and a position will be fixed correctly. It will calculate automatically and a position will be fixed correctly. AD is parts and BC is any portions by the side of the board. However, ABCD must have each in the same position. CDPS is Coordinating Designation Positioning System (Patent is under app.)

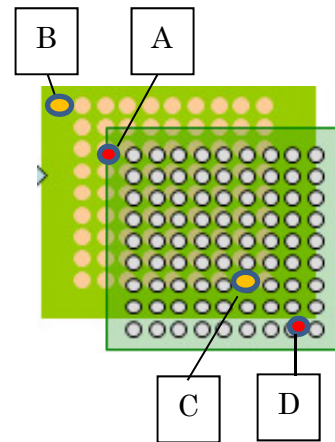

Because positioning is automatic, the trouble by a worker can be kept out.

*MS9000SE-ECS External Camera System (Option)

As for external camera system, a 0.3M pixel color image is seen on the monitor screen.

It is necessary to reworking of chip components.

MS9000SE-DECS has 2M pixels camera with 400mm maximum focus lens. And a free-lock stand with a powerful magnet is attached for it.

Moreover, the image data can be stored in SD, It is photo and movie also. They are capturing is possible.

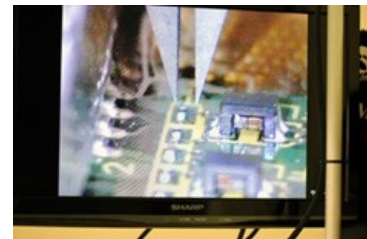
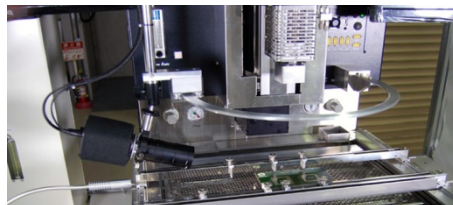

The stable image is got because there is the safety rail of the camera in MS9000SE-DECS with Rail.

***Main Specifications (MS9000SE) (★ : optional spec.)**

| Item | Description |
|------------------------|---|
| Board Size | Up to 400x500mm |
| Board Space | Top: $\leq 40\text{mm}$ / Bottom $\leq 25\text{mm}$ |
| Board Holder | 4 arms Lock |
| BGA Size / Chip Parts | 1mm~50mm□ / 01005 ~ 0805 inch / 0402 ~ 2012mm |
| ★(Chip Size Parts) | 01005(0402)~0805(2012) / Space: $\geq 200 \mu\text{m}$ / Height: $\leq 10\text{mm}$ |
| Top Heater | Hot Air 1040VA (★ IR 800VA) |
| By N2 Gas | Possible |
| Wide Bottom Heater | IR Halogen 2700VA 280x500mm (★450VA x 6) |
| Temp. Controller | Sensor K type for Controller x 2 / Measuring x 4/ 6 colors |
| Auto-Profiler | Windows7/1GHz /SSD/120GB w/Wireless Key Bard & Touch Panel |
| Temp. Control Step | A mode:4+1 / M mode:6 |
| Ranges | 300°C x 650 seconds max. (M mode: 500 sec.) 6CH 6 Colors Graph |
| Operation | Wireless-Key-Board & Touch-P |
| Control Data Capacity | 50GB |
| Analyzer Software | Analysis Output A4 Color. |
| File Save | 35KB/file x Up to 50GB |
| Z Axis Control | Stepping Motor Control 10 μm /pulse |
| Vertical Accuracy | $\leq 10 \mu\text{m}$ |
| Operation | Top Origin/Joystick operation by 4 steps |
| Safety Limit | Load Sensor $\leq 40\text{g}$ |
| XY Table | Pulse motor control with Joystick x 5 Steps |
| Level Accuracy | $\leq 10 \mu\text{m}$ / Operation : $\geq 10 \mu\text{m}$ /pulse |
| Moving Range | 300 x 400mm (400 x 500mm) |
| Vision System | Optical-Positioning-System |
| ★Semi-Auto Positioning | CCD 2Mx2 (Two Images composition auto-system) |
| Monitor | 22inch LCD (NTSC) |
| External Camera | (0.3M Pixel CCD Camera with Universal-Holder) |
| Dimension | Body:570W x 850D x 870Hmm (w/monitor: 1050W x 850D x 910Hmm) |
| Weight | 90 Kg Approx. |
| Power | AC200~240V 4.2KVA Single Phase |
| Air | 0.5~0.8Mpa Dry & Clean 150L/min or more. |
| Safety Control. | Pass-word, Emergency SW / Interlock etc. System $\leq 650^\circ\text{C}$ |

The specifications are subject to change without notice

*Accessories:

The process for the reworking required many kinds of the Tools, attachments and also other machines. We are preparing all of them required for the process.

Standard Accessories:

1. Board support Tool.
2. Under board support pins system (2 rails and 4 pins)
3. Power Cable (3 cores) x 1 (approx. 5M)
4. Air Tube x 1 (6mmD approx. 3M)
5. Solder Printing Tool SND-N x 1 (Metal mask & Transcriber)
6. Nozzle x 1 (MS9000SEnz3636) with a Thermal Management Board.
7. Center Vacuum bit x 1 set (S/M/L)
8. Instruction Manual x 1



Under Support



Reflow Nozzle



Center Vacuum Bit.

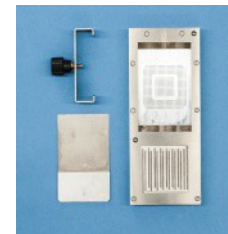

Solder Printing Tool

Optional Accessories:

1. IR Heater Unit **MS9000SE-IRH.**
2. Tweezers Nozzle: **MS9000SE-CHU.**(01005/0201/0402(0402/0603/1005mm)
3. External Camera System: **MS9000SE-ECS (with camera stand)**
4. External Camera System: **MS9000SE-DECS (with camera rail)**
5. Solder Cleaning Nozzle: **MS9000SE-TCN**
6. Full-Auto Rework System: **MS9000SE-FAU**
7. Reflow Nozzle: It chooses according to the size. **0000Z10/35**
8. Solder print pin for Chip: **MS9000SE-CPP**
9. Pic-up Pin for Chip: **MS9000SE-CPTP**
10. Thermal Radiation Unit **MS9000SE-TRM**
11. Under-Fill- Nozzle: **MS9000SE-UFN**
12. Sensor Kit: **ST50K** (For surface temperature sensing)
13. Metal Mask Cleaner: **RBC/SND-MCL (For SND-N)**
14. Re-Balling Tool **RBC-1** (Re-balling & Printing)
15. N2 Generator **MS15N**
16. X ray Inspection System **MSX600.** (Desk Top Type)
17. X ray Inspection System **MSX1500.** (Tomogram is also Possible)
18. Compressor for RBC-1: **RBC-1VCM**
19. L Size Re-balling Tool **RBC-100** (For up-to 100x100mmBGA)



MS9000SE-CLN



MS9000SE-DECS w/rail



MS9000SE-DECS w/stand



RBC-1



MS9000SE-CHU



0000ZD0/35

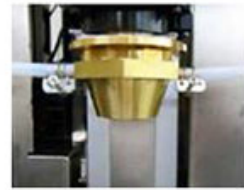

MS9000SE-UFN



MSX600



MS9000SE-IRH



MS9000SE-CLH



MS9000SE-CDH / Pin



RBC-1C



MS15N



RBC-1-VCM